



Quick Reference Specifications:

Dimensions: 22.8"(H)X 21.8"(L)X 12.1(W)

Weight: 88.6 lbs (full)

Electrical Requirements: Volts: 115/Watts: 1700/Circuit Amps: 20

Plumbing Requirements: Flow: 30GPH (minimum) Pressure: 20psi (minimum) Hardness: 3 GPG (maximum) Fitting: 3/8" w/shut-off

Drainage Requirements: Open gravity drain of 1.25" ID (min) within 4 feet of machine.

The following information will assist you in preparing your location for the installation of your equipment. Please make sure everything is prepared to these specifications *prior* to scheduling your installation. Once everything is complete, check the appropriate **boxes** and sign the bottom of the form.

COUNTER SPACE REQUIREMENTS: CONFIRMED – 2.5" ACCESS HOLE IS IN PLACE

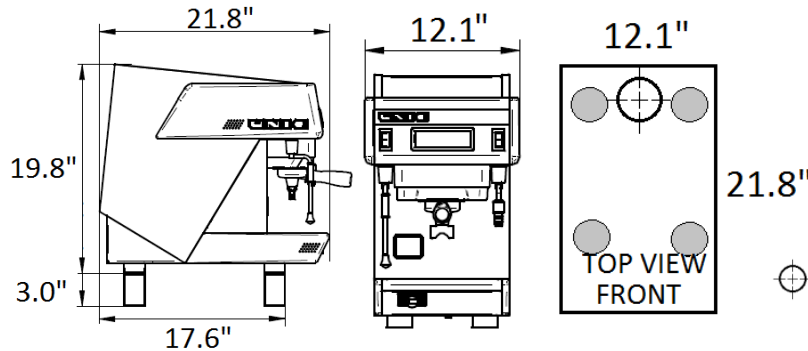

PLEASE NOTE: There are 3 inch leg extensions shipped with the machine, but not installed. Their use is optional, but highly recommended for ease of cleaning under the unit.

⊕ = 2.5" HOLE IN COUNTER TOP FOR ELECTRICAL AND PLUMBING CONNECTIONS

WATER REQUIREMENTS: CONFIRMED - WATER HARDNESS LEVEL _____ GPG



- *Machine must be supplied with a minimum of 30 Gallons per hour @ 20 PSI.
- *For examples of appropriate supply fittings, see examples at left.
- *If water hardness levels exceed 3 GPG (Grains per Gallon) a water softener **MUST** be installed. Exceeding these levels will void the manufacturer's warranty. (Check appropriate box below)
- I have tested the water hardness and it is 3 GPG or less (see above).
- I already have a suitable water softener and its output is 3 GPG or less (see above).
- I have tested the water hardness level and it is written above. Please supply me with the appropriate water softener at time of installation.

ELECTRICAL REQUIREMENTS: CONFIRMED

Dedicated 20 AMP Plug within 4 feet of installation location.
PLEASE NOTE: A proper 20 AMP plug will be configured as shown on the RIGHT. Plugs with only vertical inputs are only rated for 15 AMPS and will not work.



DRAINAGE REQUIREMENTS: CONFIRMED

Access to open gravity drain no smaller than 1.25" ID (Inner Diameter). Drain **MUST** be within 4 feet of the machine for proper drainage.

By signing below, I am confirming that all installation requirements have been met. I also understand that if all the requirements have not been met, I may be subject to additional installation and travel charges beyond the original estimate.

Signature _____ Printed Name _____ DATE _____